

LEISTER

PLASTIC WELDING

SEAMTEK 900 AT

**Maximum flexibility
for your specific
application**









www.leister.com

We know how.

SEAMTEK 900 AT: Maximum flexibility for your specific application

The intelligent construction of the SEAMTEK 900 AT makes practically any welding application possible. Thanks to the well-thought-out multi-arm system, the machine can be set to a specific configuration for the application in record time. The huge selection of various drive wheels, nozzles and guides guarantees maximum flexibility. The intuitive operation of the user interface takes place entirely via touchscreen and permits simple adjustment of the regulated parameters.

1		<p>Intuitive</p> <ul style="list-style-type: none"> • All parameters can be modified via touchscreen • Complete regulation of all parameters 	
2		<p>Application-friendly</p> <ul style="list-style-type: none"> • Tool-free nozzle adjustment • Rapid wheel replacement 	
3		<p>Pedestal</p> <ul style="list-style-type: none"> • Overlap welding • Hem and piping welding • 3D / Inflatable welding • Tape welding 	
4		<p>Quickarm</p> <ul style="list-style-type: none"> • Endless welding of pipes and hoses • Overlap welding 	
5		<p>Sidearm</p> <ul style="list-style-type: none"> • Circumference welding • Tape welding • Sealing of end caps 	
6		<p>Tape Delivery System</p> <ul style="list-style-type: none"> • Application of seam sealing tape • Welding of reinforcement tape • Welding of hot melt adhesive tape 	

Leister SEAMTEK 900 AT



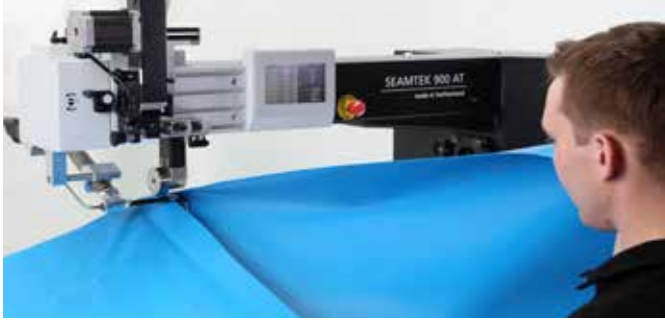

Easy, economical and safe welding.



Example: Tents

Welding machine

SEAMTEK 900 AT

- Multi-arm system guarantees great flexibility
- Welding parameters are digitally regulated
- Intuitive user interface
- Quiet operation
- Test mode for rapid parameter determination
- Drive wheels and guides can be quickly changed
- Maintenance-free and durable

Application



Inflatables



Flood protection



Advertising



Seam sealing for Outdoor Equipment

Technical data

Voltage	V~	230 / 240
Power	W	4500
Temperature	°C	120 – 700
Speed	m/min	0.1 – 30
Size (L × W × H)	mm	1500 × 702 × 1500
Weight	kg	238 kg Base 268 kg Fully loaded
Required air pressure	bar	6.2
Welding seam width	mm	8 – 64

Article No.:

155.555	SEAMTEK 900 AT Base version with pedestal, 2 steel pressure rollers 25 mm, standard nozzle 25 mm
155.777	Quick arm
155.666	Side arm
155.888	Tape Delivery System (TDS)
156.314	Transport Box

Accessories SEAMTEK 900 AT

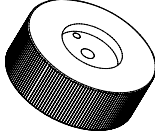
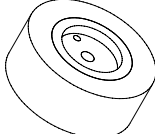
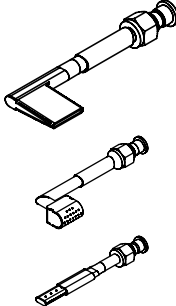
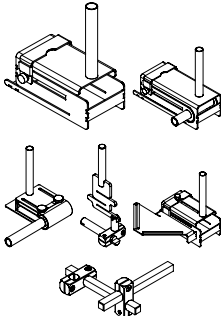
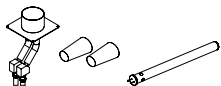
	Wheel, Steel, Ø 63.5 mm 155.392 8 mm 155.393 13 mm 155.863 19 mm 154.593 25 mm 155.864 38 mm 155.394 50 mm 155.865 57 mm 154.619 64 mm
	Wheel, Silicone, 50A, Ø 63.5 mm 155.401 13 mm 155.402 19 mm 155.403 25 mm 155.404 38 mm 155.405 50 mm 155.406 57 mm 155.407 64 mm
	SEAMTEK Nozzle 157.808 8 mm (Low Flow) 157.799 13 mm (Low Flow) 151.598 13 mm 151.601 19 mm 151.597 25 mm 151.608 38 mm 151.599 50 mm 151.850 55 mm 151.600 64 mm 152.941 Closing nozzle with angle 152.956 Hem nozzle 153.730 Taping Nozzle 25 mm 152.931 Adjustable taping nozzle 50 mm
	SEAMTEK Guide 155.660 Adjustable overlap guide, 0 – 64 mm 155.530 Adjustable hem-/ piping guide 0 – 50 mm 155.760 Adjustable hem-/ piping guide 0 – 60 mm, for heavy materials 155.380 Open Hem/Pocket Guide up to 110 mm 155.540 Modular 3D guide 156.760 Overlap guide from the left 156.770 Adjustable hot melt adhesive tape guide 155.400 Holder system for guides 156.780 Overlap guide for quick arm
	155.410 Connection adapter for fume extraction 156.777 Air filter set 150.581 Heating Element 230V/3600W

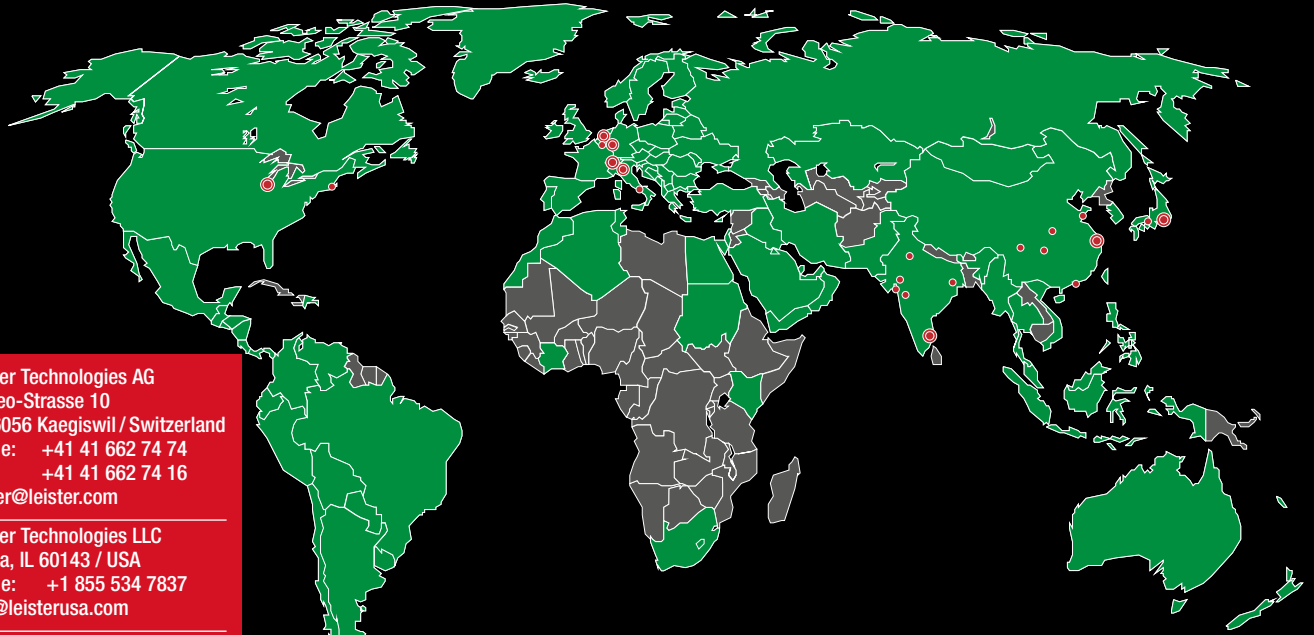

Leister Technologies AG
Galileo-Strasse 10
CH-6056 Kaegiswil / Switzerland
phone: +41 41 662 74 74
fax: +41 41 662 74 16
leister@leister.com

Leister Technologies LLC
Itasca, IL 60143 / USA
phone: +1 855 534 7837
info@leisterusa.com

Leister Technologies Ltd.
Shanghai 201 109 / PRC
phone: +86 21 6442 2398
leister@leister.cn

Leister Technologis KK
Osaka 564-0051 / Japan
phone: +81 6 6310 62 00
sales-japan@leister.com

Leister Technologies Benelux BV
3991 CE Houten / Nederland
phone: +31 (0)30 2199888
info@leister.nl

Leister Technologies Italia s.r.l.
20090 Segrate / Italia
phone: +39 02 2137647
sales@leister.it

Leister Technologies India Pvt
600 041 Chennai / India
phone: +91 44 2454 3436
info@leister.in

Leister Technologies Deutschland GmbH
D-58093 Hagen / Germany
phone: +49-(0)2331-95940
info.de@leister.com

We are local. Worldwide.

Our close worldwide network of more than 130 Sales and Service Centers in more than 100 countries.

- | | | | | | |
|---|--|---|---|--|---|
| Europe:
Andorra
Austria
Belgium
Cyprus
Denmark
Finland
France
Germany
Greece
Iceland
Ireland
Italy
Luxembourg
Malta
Monaco
Netherlands
Norway
Portugal
Liechtenstein
San Marino
Spain | Sweden
Switzerland
Turkey
United Kingdom
Vatican
Albania
Armenia
Azerbaijan
Belarus
Bosnia-Herzegovina
Bulgaria
Croatia
Czech Republic
Estonia
Georgia
Hungary
Kosovo
Latvia
Lithuania
Macedonia
Moldova
Montenegro | Poland
Romania
Russia
Serbia
Slovakia
Slovenia
Ukraine

America:
Canada
Mexico
USA
Belize
Costa Rica
El Salvador
Guatemala
Honduras
Nicaragua
Panama
Argentina
Bolivia
Brazil | Chile
Colombia
Ecuador
Peru
Venezuela

Central Asia:
Kazakhstan
Kyrgyzstan
Tajikistan
Turkmenistan
Uzbekistan

Middle East:
Bahrain
Iran
Iraq
Israel
Jordan
Qatar
Saudi Arabia
U.A.E | Africa:
Algeria
Botswana
Egypt
Ivory Coast
Kenya
Lesotho
Libya
Malawi
Morocco
Mozambique
Namibia
South Africa
Swaziland
Tunisia
Zambia
Zimbabwe | Indonesia
Japan
Korea
Macao
Malaysia
Myanmar
Mongolia
Pakistan
Philippines
Singapore
Taiwan
Thailand
Vietnam

Oceania:
Australia
New Zealand |
|---|--|---|---|--|---|

© Copyright by Leister, Switzerland

Distributor Addresses: